

WTM

Monoblock Centrifugal Pumps



FEATURES

- WTM pumps are non-self-priming, single stage, centrifugal volute pumps with axial suction part, radial discharge port and horizontal shaft.
- Inlet and outlet flanges are PN10 in compliance with UNI2236 and DIN2532
- Dimensions and rated performance are according to EN733 (ex DIN 24255) and UNI 7467
- Close-coupled centrifugal pumps, electric motor with extended shaft directly connected to the pump up to 7,5 kW (included) stub-shaft construction for standard motors from 11 kW to 55 kW. Motor performance in compliance with CEI 2-3 / IEC 34.1
- Discharge ports DN32 to DN80
- The pumps are of the back pull-out design enabling removal of the motor, coupling, bearing bracket and impeller without disturbing the pump housing or pipe work.
- Anti-clockwise rotation when facing pumps suction port
- Mechanical seal in compliance with DIN 24960
- Lubricated by internal recirculating pumped liquid
- Maximum operating pressure is 12 Bar
- Maximum liquid temperature -10°C to 85°C, upon request: -20°C to 120°C
- Maximum ambient temperature 40°C
- IP54 protection, insulation class F
- Overload protection
- Counter Flange available on request
- Variable speed by optional "WDRIVE" drive.

APPLICATIONS

WTM is multi-purpose pump suitable for a variety of different applications demanding reliable and cost-efficient supply. WTM pumps are used in five main fields of application.

Water Supply

Besides general water supply in municipal and industrial water works the WTM pumps are used for these specific applications.

- Filtration and transfer at water works
- Pressure boosting in mains
- Pressure boosting in high-rise buildings, hotel, etc.
- Pressure boosting in industrial buildings
- Various swimming bath applications

Industrial pressure boosting

- Industrial washing and cleaning systems
- Industrial wash downs systems
- Vehicle washing tunnels
- Fire-fighting systems

Industrial Liquid Transfer

- Cooling and air-conditioning systems
- Boiler-feed and condensate systems
- Aqua farming
- Industrial heating systems
- District heating plants

HVAC

- Heating Systems
- Ventilation systems
- Air-conditioning systems

Irrigation

- Field irrigation
- Sprinkler irrigation
- Drip-feed irrigation

WTM

Monoblock Centrifugal Pumps

WTM 32/125

2900 rpm

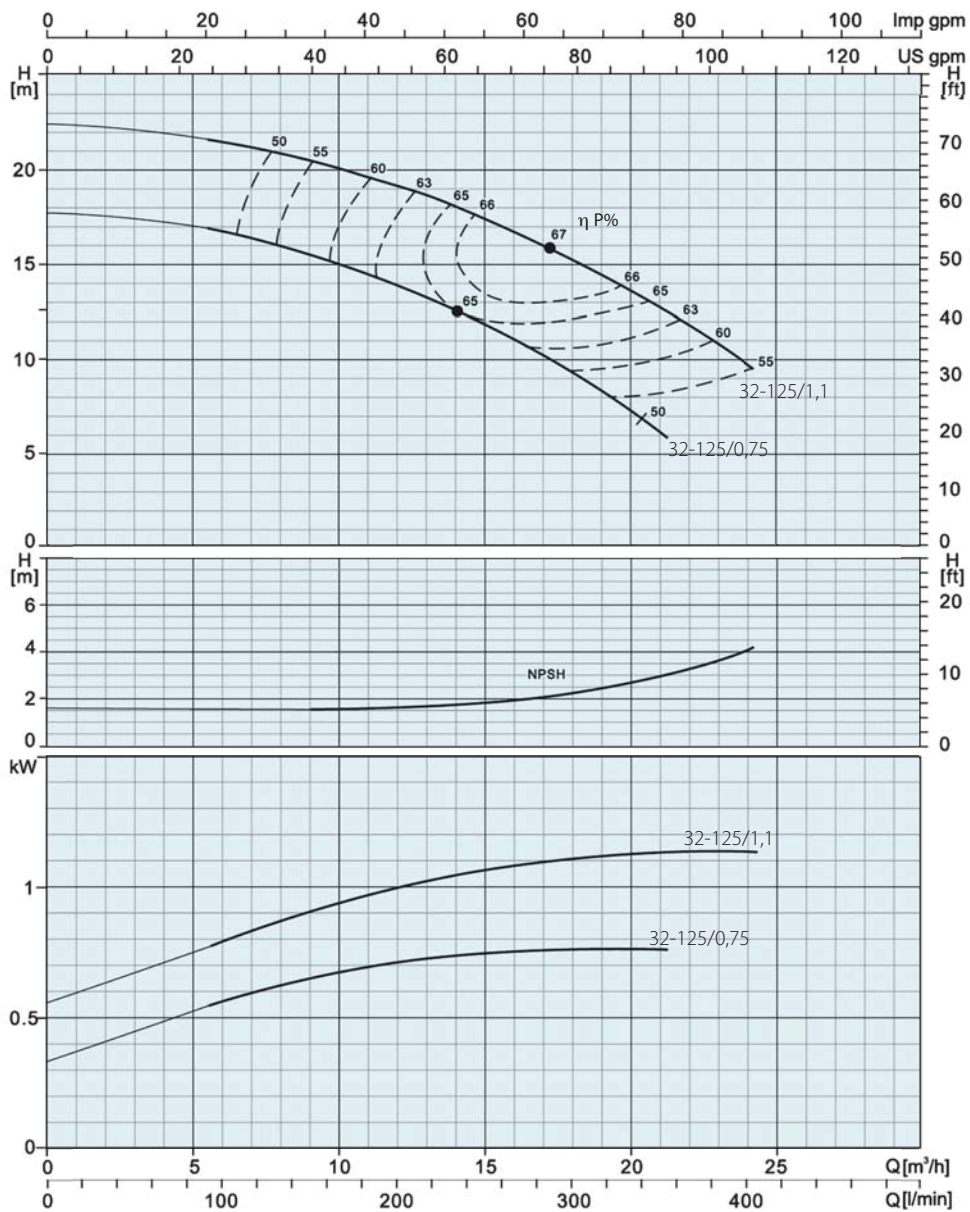

MODEL	3 PH 400 V A	P ₂		l/min Q m³/h	0	100	150	250	300	400	Weight kg	Part	Material
		kW	HP		0	6	9	15	18	24			
WTM 32-125/0,75	2,12	0,75	1	H (m)	17,5	16,7	15,3	11,9	9,1	-	23,8	Pump Body	Cast Iron
WTM 32-125/1,1	3,1	1,1	1,5		22	21,4	20,3	17,1	15	9,8	26	Impeller	AISI 304
												Shaft	AISI 304
												Mechanical Seal	CA/SIC/NBR

WTM

Monoblock Centrifugal Pumps

WTM 32/160

2900 rpm

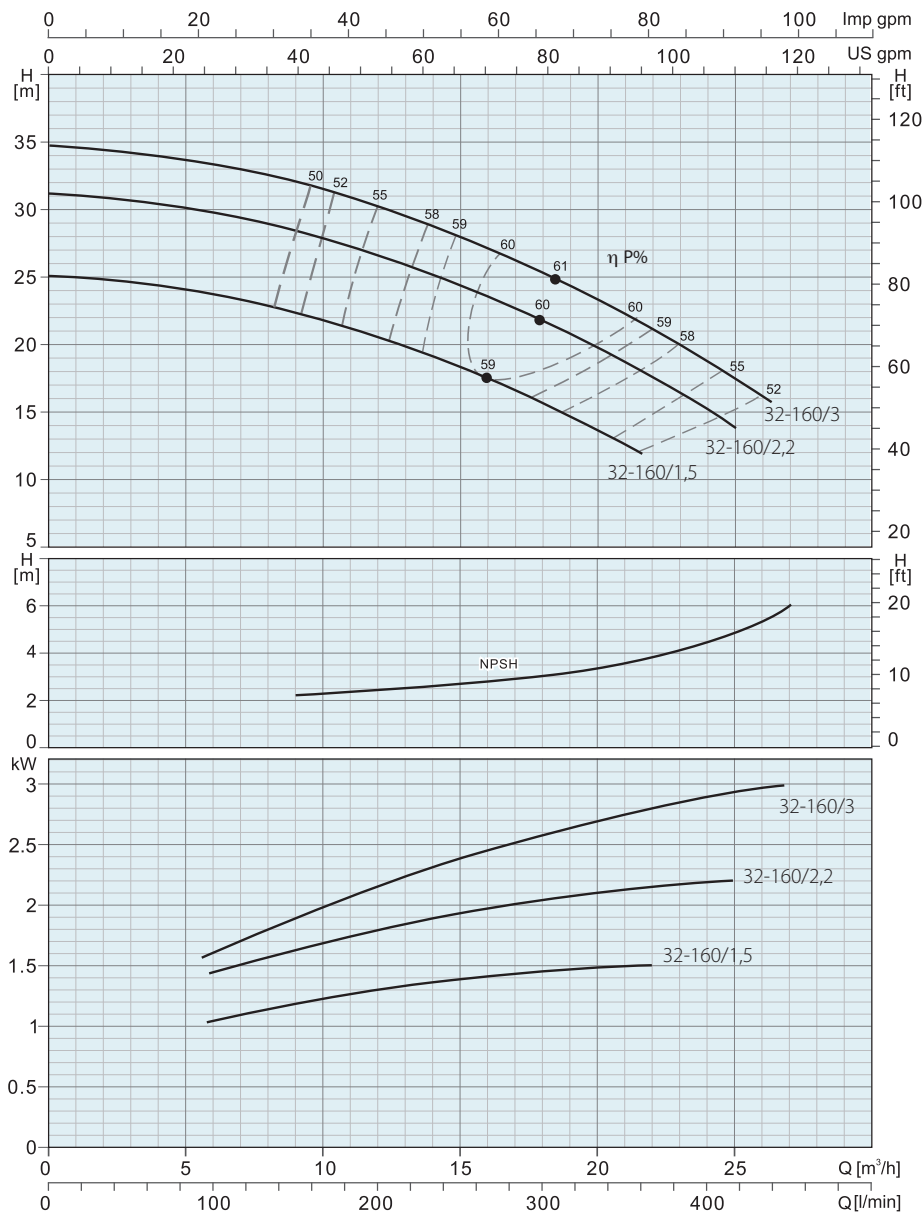

MODEL	3 PH 400 V A	P ₂		l/min Q m³/h	0	100	150	250	300	400	450	Weight kg	Part	Material
		kW	HP		0	6	9	15	18	24	27			
WTM 32-160/1,5	3,36	1,5	2	H (m)	25,4	23,7	22,2	18,1	15,6	-	-	30,1	Pump Body	Cast Iron
WTM 32-160/2,2	4,9	2,2	3		31	29,8	28,3	24,3	21,6	15	-	31,3	Impeller	AISI 304
WTM 32-160/3	6,5	3	4		35	33,2	32	28	25,3	18,7	15	41	Shaft	AISI 304
													Mechanical Seal	CA/SIC/NBR

WTM

Monoblock Centrifugal Pumps

WTM 32/200

2900 rpm

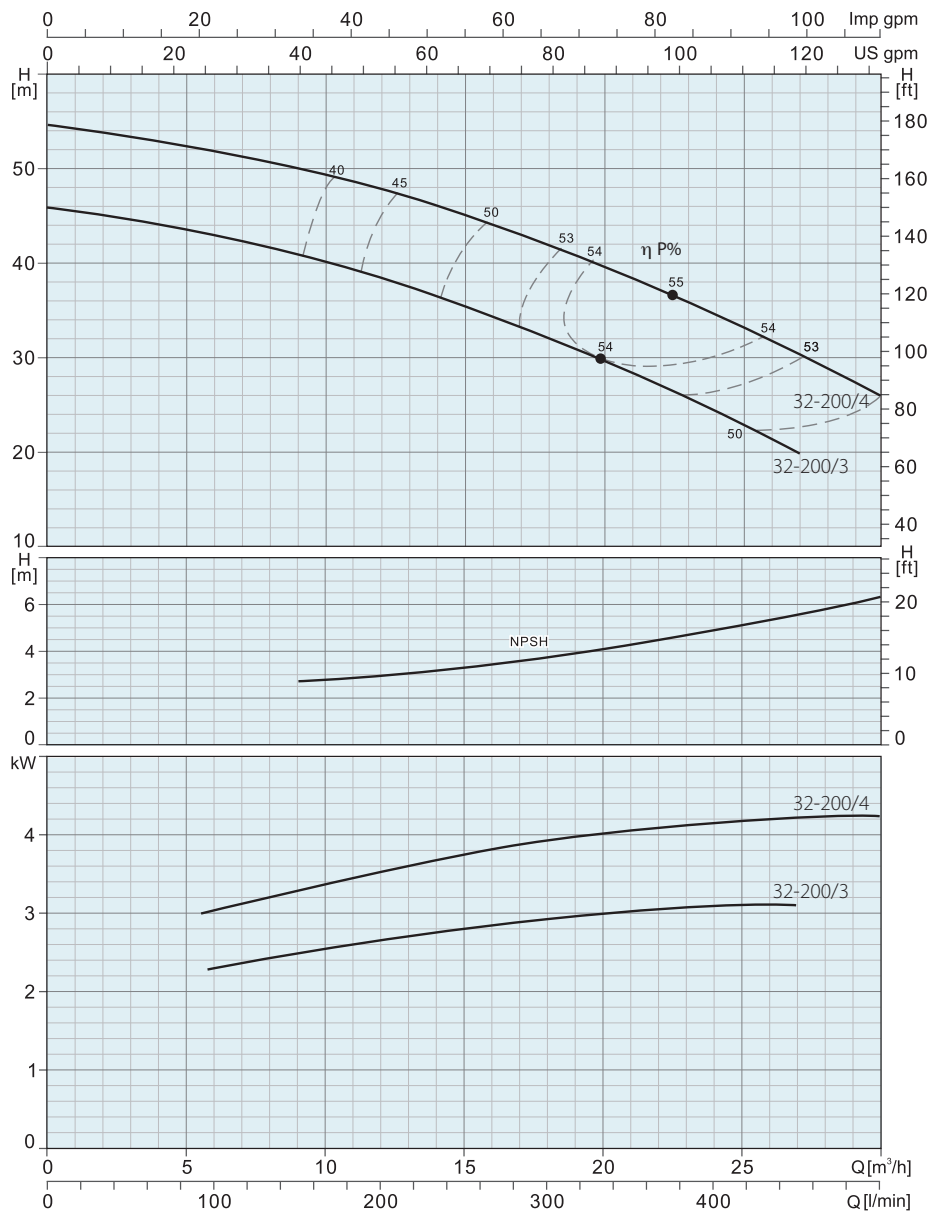

MODEL	3 PH 400 V A	P ₂		l/min Q m³/h	0	100	150	250	300	400	450	Weight kg	Part	Material
		kW	HP		0	6	9	15	18	24	27			
WTM 32-200/3	6,5	3	4	H (m)	44,2	43	40,4	35,2	32	24	19,8	47,9	Pump Body	Cast Iron
WTM 32-200/4	9,3	4	5,5		54,5	51,9	50	45	41,8	34,2	30,1		51,1	Impeller
													Shaft	AISI 304
													Mechanical Seal	CA/SIC/NBR

WTM

Monoblock Centrifugal Pumps

WTM 32/250

2900 rpm

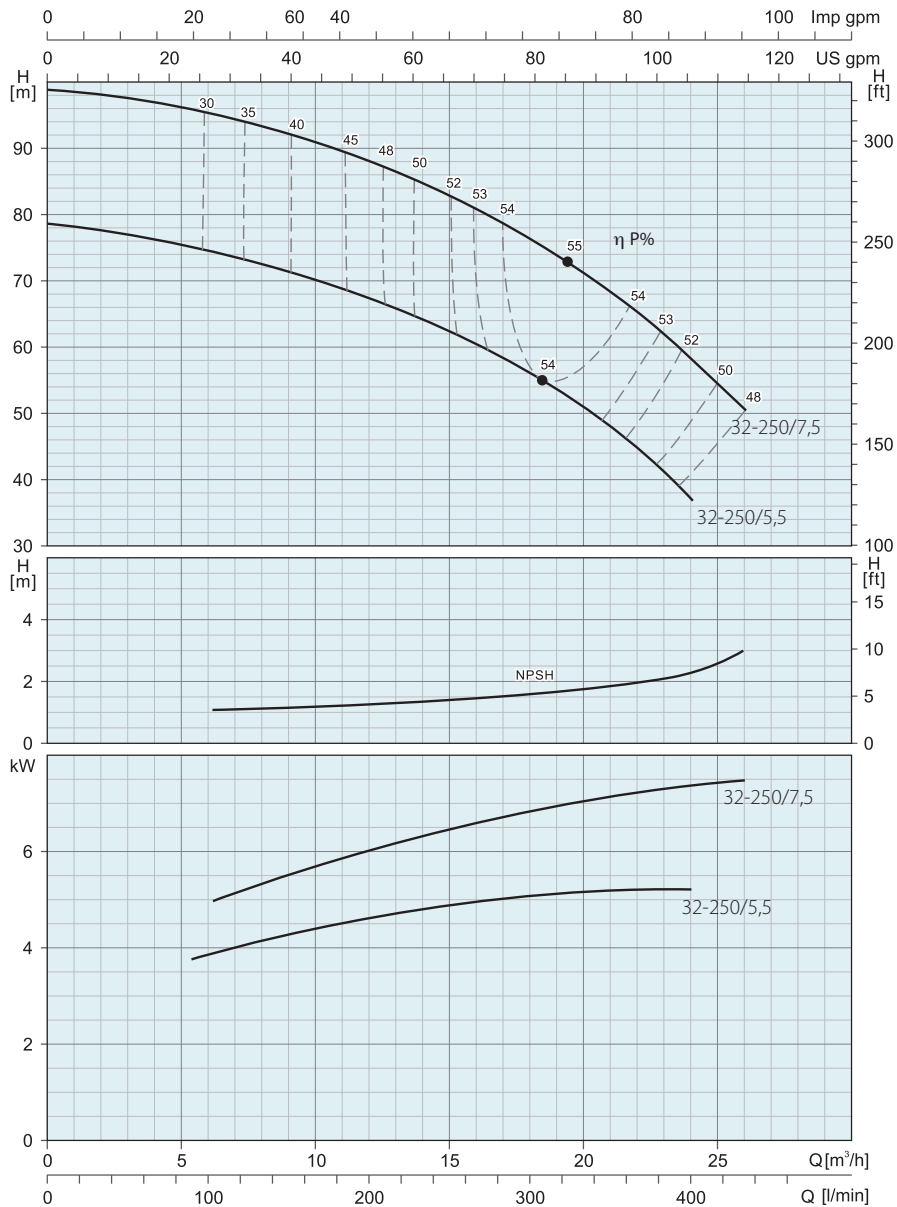

MODEL	3 PH 400 V A	P ₂		l/min Q m³/h	0	100	150	250	300	400	Weight kg	Part	Material
		kW	HP		0	6	9	15	18	24			
WTM 32-250/5,5	11,5	5,5	7,5	H (m)	79,5	74,2	71,5	62	56	37	78,9	Pump Body	Cast Iron
WTM 32-250/7,5	15,5	7,5	10		99,5	95,1	92	82,8	58	57,8		80,5	Impeller
												Shaft	AISI 304
												Mechanical Seal	CA/SIC/NBR

WTM

Monoblock Centrifugal Pumps

Dimensions

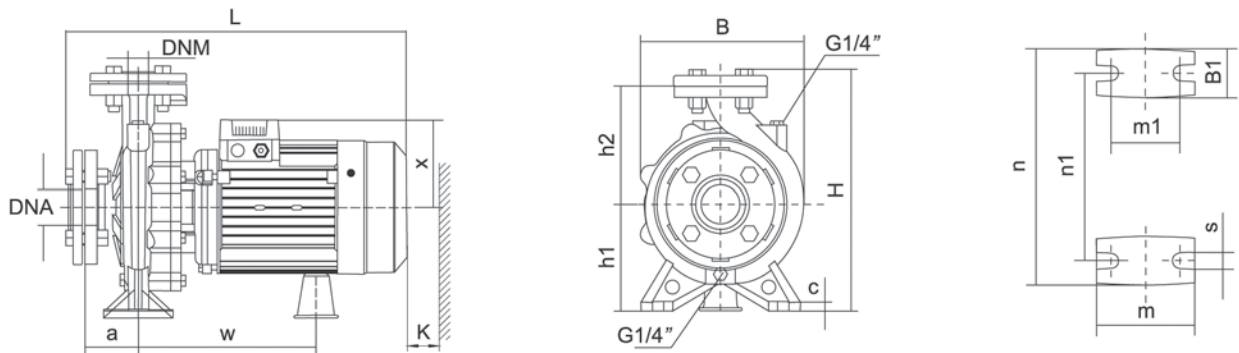

MODEL	DNM	DNA	a	h2	w	x	B1	c	h1	m	m1	n	n1	s	B	H	L	K
WTM 32-125/0,75	32	50	80	140	223	113	48	12	112	100	70	190	140	17	192	281	428	85
WTM 32-125/1,1	32	50	80	140	223	113	48	12	112	100	70	190	140	17	192	281	428	85
WTM 32-160/1,5	32	50	80	160	231	123	50	16	132	100	70	240	190	17	240	321	430	95
WTM 32-160/2,2	32	50	80	160	266	141	50	16	132	100	70	240	190	17	240	321	496	95
WTM 32-160/3	32	50	80	160	266	141	50	16	132	100	70	240	190	17	240	321	496	95
WTM 32-200/3	32	50	80	180	258	127	48	12	132	100	70	240	190	17	248	369	490	95
WTM 32-200/4	32	50	80	180	258	127	48	12	132	100	70	240	190	17	248	369	490	95
WTM 32-250/5,5	32	50	100	230	254	180	65	14	180	125	95	320	250	17	320	439	557	60
WTM 32-250/7,5	32	50	100	230	254	180	65	14	180	125	95	320	250	17	320	439	587	60
WTM 40-125/1,1	40	65	80	140	255	127	45	12	112	100	70	210	160	17	218	282	489	95
WTM 40-125/1,5	40	65	80	140	225	127	45	12	112	100	70	210	160	17	218	282	489	95
WTM 40-125/2,2	40	65	80	140	225	127	45	12	112	100	70	210	160	17	218	282	489	95
WTM 40-160/3	40	65	80	168	238	127	48	12	132	100	70	240	190	17	249	330	494	105
WTM 40-160/4	40	65	80	168	238	127	48	12	132	100	70	240	190	17	249	330	494	105
WTM 40-200/5,5	40	65	100	180	259	180	50	12	160	100	70	264	212	17	275	370	553	105
WTM 40-200/7,5	40	65	100	180	259	180	50	12	160	100	70	264	212	17	275	370	583	105
WTM 50-125/2,2	50	65	100	160	262	127	50	12	132	100	70	260	190	17	243	322	518	100
WTM 50-125/3	50	65	100	160	262	127	50	12	132	100	70	260	190	17	243	322	518	100
WTM 50-125/4	50	65	100	160	262	127	50	12	132	100	70	260	190	17	243	322	518	100
WTM 50-160/5,5	50	65	100	180	262	180	52	12	160	100	70	264	212	17	272	370	556	100
WTM 50-160/7,5	50	65	100	180	262	180	52	12	160	100	70	264	212	17	272	370	586	100
WTM 65-125/4	50	65	100	180	265	180	68	14	160	125	95	280	212	17	283	372	564	100
WTM 65-125/5,5	50	65	100	180	265	180	68	14	160	125	95	280	212	17	283	372	564	100
WTM 65-125/7,5	50	65	100	180	265	180	68	14	160	125	95	280	212	17	283	372	594	100

WTM

Monoblock Centrifugal Pumps

Dimensions

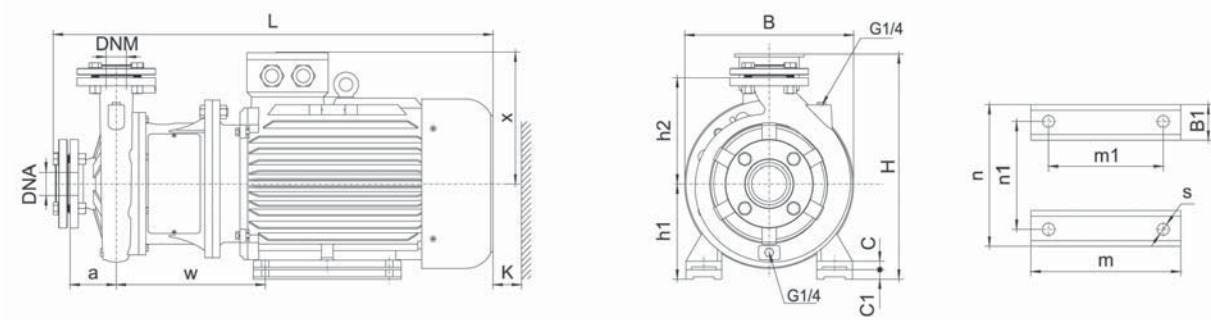

MODEL	DNM	DNA	a	h2	w	x	B1	C	C1	h1	m	m1	n	n1	s	B	H	L	K
WTM 40-250/9,2	40	65	100	225	310	260	65	20	20	180	260	210	320	254	15	350	440	845	110
WTM 40-250/11	40	65	100	225	310	260	65	20	20	180	260	210	320	254	15	350	440	845	110
WTM 40-250/15	40	65	100	225	310	260	65	20	20	180	260	210	320	254	15	350	440	845	110
WTM 50-200/9,2	50	65	100	200	310	260	65	20	-	160	260	210	320	254	15	350	420	845	120
WTM 50-200/11	50	65	100	200	310	260	65	20	-	160	260	210	320	254	15	350	420	845	120
WTM 50-250/15	50	65	100	225	310	260	65	20	20	180	260	210	320	254	15	350	440	845	110
WTM 50-250/18,5	50	65	100	225	310	260	65	20	20	180	304	254	320	254	15	350	440	895	110
WTM 50-250/22	50	65	100	225	323	275	70	25	-	180	311	241	355	279	15	350	455	925	110
WTM 65-160/9,2	65	80	100	200	310	260	65	20	-	160	260	210	320	254	15	350	420	845	125
WTM 65-160/11	65	80	100	200	310	260	65	20	-	160	260	210	320	254	15	350	420	845	125
WTM 65-160/15	65	80	100	200	310	260	65	20	-	160	260	210	320	254	15	350	420	845	125
WTM 65-200/15	65	80	100	225	310	260	65	20	20	180	260	210	320	254	15	350	440	845	125
WTM 65-200/18,5	65	80	100	225	310	260	65	22	20	180	304	254	320	254	15	350	440	895	125
WTM 65-200/22	65	80	100	225	323	275	70	25	-	180	311	241	355	279	15	355	455	925	125
WTM 65-250/22	65	80	100	250	253	275	70	25	-	180	311	241	355	279	15	355	455	956	125
WTM 65-250/30	65	80	100	250	365	305	70	30	-	200	369	305	395	318	19	400	505	1026	125
WTM 65-250/37	65	80	100	250	365	305	70	30	-	200	369	305	395	318	19	400	505	1026	125
WTM 80-160/11	80	100	125	225	315	260	65	20	-	160	260	210	320	254	15	350	420	870	130
WTM 80-160/15	80	100	125	225	315	260	65	20	-	160	260	210	320	254	15	350	420	870	130
WTM 80-160/18,5	80	100	125	225	315	260	65	20	-	160	304	254	320	254	15	350	420	926	120
WTM 80-200/22	80	100	125	250	352	275	70	25	-	180	311	241	355	279	15	355	461	946	120
WTM 80-200/30	80	100	125	250	365	305	70	30	-	200	369	305	395	318	15	400	505	1016	120
WTM 80-250/37	80	100	125	280	365	305	70	30	-	200	369	305	395	318	15	400	508	1016	120
WTM 80-250/45	80	100	125	280	381	330	75	30	-	225	404	311	435	356	19	450	555	1067	120
WTM 80-250/55	80	100	125	280	433	365	80	30	30	280	450	349	490	406	24	550	646	1160	120

WTM

Monoblock Centrifugal Pumps

Dimensions

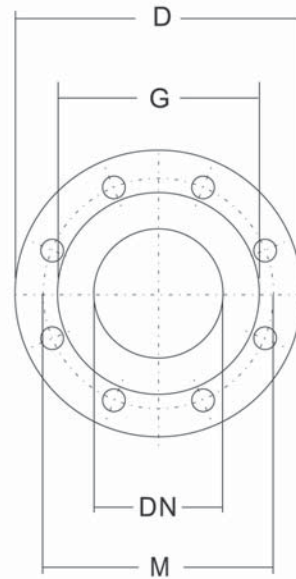
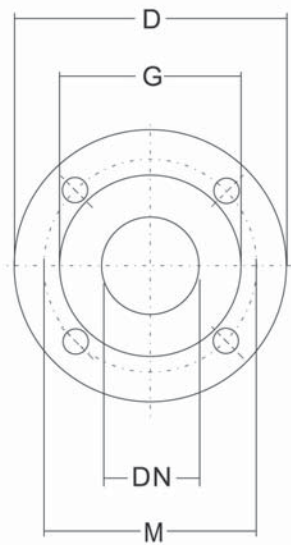

PN16 Flanges

DN	D	M	G	Holes		Max. Thickness
				N°	Ø	
32	140	100	78	4	18	18
40	150	110	88	4	18	18
50	165	125	102	4	18	20
65	185	145	122	4	18	20

PN16 Flanges

DN	D	M	G	Holes		Max. Thickness
				N°	Ø	
80	200	160	138	8	18	22
100	220	180	158	8	18	22